

Catalogue

One	Summarize	
1.1	General safety recommendations.....	1
1.2	Features.....	1
1.3	Specification	1
1.4	Overall dimension.....	2
Two	Balancer installation.....	2
Three	Structure.....	4
3.1	Main structure.....	4
3.2	Display panel structure.....	4
Four	Operation	
4.1	Start	5
4.2	Wheel installation.....	5
4.3	Data inputting.....	6
4.3.1	Automatic inputting.....	6
4.3.2	Manual inputting.....	6
4.4	Balance function selection	
4.4.1	DYN balance	8
4.4.2	STA balance.....	9
4.4.3	ALU balance.....	10
4.4.4	MOT balance.....	12
4.4.5	OPT balance.....	13
4.4.6	SPI balance.....	14
Five	Set program.....	15
5.1	g/ounce transfer.....	15
5.2	Scale calibration.....	15
5.3	Weight calibration.....	16
Six	Common trouble information and shooting	17
6.1	Trouble code information and shooting.....	17
6.2	Other trouble and shooting.....	17
Seven	Connection drawing	18
Eight	Explode drawing	19

One Summarize

1.1 General safety recommendations

- The wheel balancer should not be used for purposes other than those described in the instruction manual.
- Under no way should the wheel balancer be modified expect for those modifications made explicitly by the dealer.
- Never remove the safety devices. Any work on the machine should only be carried out by specially personnel.
- Before starting the wheel balancer cycle, make sure that the wheel is securely locked on the adapter.
- The operator should avoid wearing clothes with flapping edges, make sure that unauthorized personnel do not approach the machine during the work cycle.
- Never pull the spindle shaft when moving, installing or operating the machine. Otherwise, the spindle shaft may be damaged permanently.
- While the wheel rotating, never touch the wheel to avoid damage or affect the measuring result.

1.2 Feature

- The balancer is suite for 8-23" aluminum alloy wheel rim
- Standard calibration function may eliminate the measurement deviation and ensure the test accuracy.
- DYN balance, STA balance, ALU 7 modes balance and MOTO balance, OPT balance, SPI balance, are available to various wheels.
- Many modes display make the shift of g/ounce, mm/inch.
- Automatic sleep and single key awake function reduces the power consumption and prolongs the service life.

1.3 Main specification

Item	Specification	Item	Specification
Power Supply	AC230V/110V	Max wheel width	540mm
Power consumption	≤250W/ running、≤15W / waiting	Max rim diameter	940mm
Balancing speed	310r/min	Max wheel mounting distance	235mm
Balancing accuracy	≤255 g or 90 oz	Measuring error	≤1%
Balancing cycle	Average 7s	noise	≤70db
Wheel width	1.5—20"	Net weight	128kg
Rim diameter	8—23"	Working circumstance	Temperature 0℃ ~50℃, relative humidity ≤85%
Wheel weight	≤60kg	Storage and transportation	Relative humidity:20%-95%; temperature:-10℃-+60℃

1. 4 Overall dimension as follow

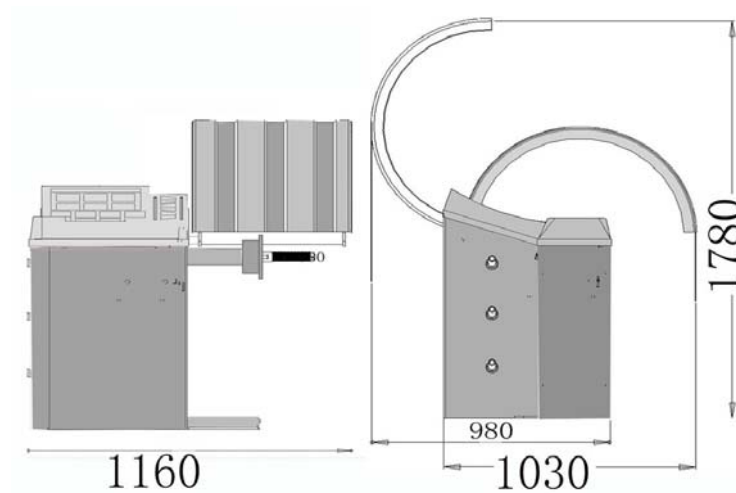

Two Balancer instalation

Step 1: Open the upper cover of the packing, check with the PACKING LIST ,make sure the wheel balancer and spareparts,documents you purchased is enough.Unbolts the wheel balancer from the bottom plate of the crate, lift it and put it carefully on the even and rigid groud. Adjust the anchor bolts till it is level and stable. (fig 2)

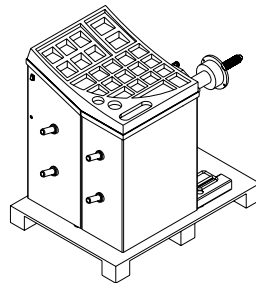

fig 2 open the package

Notice : Never pull the spindle shaft when moving,installing or operating the machine.Other wise ,the spindle shaft may be damaged permanently.

Step 2:Assemble the balance shaft, and tighten the guide screw onto the shaft deasil. (fig 3)

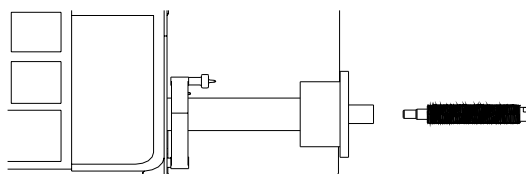

fig 3 assembly₂ the balance shaft

Step 3:assemble the hood (Optional)

Insert the protective tube into the bearing sleeve and fix the tube onto the bearing shaft with 2 bolts and nuts. (fig 4)

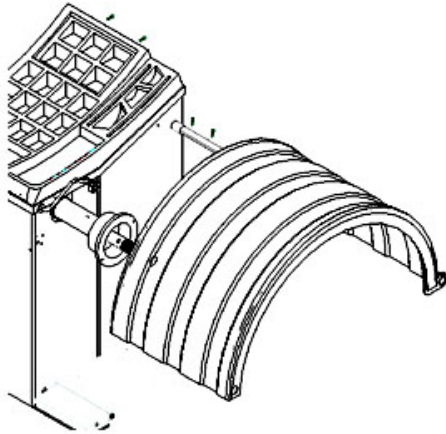

Fig 4 assemble the hood

Step 4 :connect the power.Note:Make sure the power socket is safely grounded.

Three :Structure

3.1 Main structure

the main structure of the wheel balancer is as shown in fig 5

- 1、 Power switch
- 2、 Cone bracket—for hanging cones and gauge etc
- 3、 Display panel—realize communication between Machine and person
- 4、 lead box—for housing the counterweight leads
- 5、 Measuring scale—for automatic measurement of The wheel distance and rim diameter
- 6、 brake
- 7、 balance shaft—for mounting the wheel to be balanced

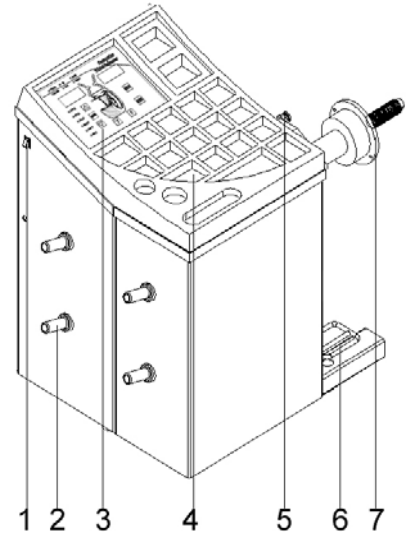

Fig 5 balancer structure

3.2 Display panel structure

The display panel of the wheel balancer is As shown in fig 6

- 1、 Display for inside wheel;
- 2、 Balance light inside;
- 3、 Balance light outside;
- 4、 Display for outside wheel;
- 5、 Upper key:choose functions and input or amend data;
- 6、 Down key: choose functions and input or amend data;
- 7、 Enter key:affirm the step;
- 8、 Transform key: Transform operations of the wheel width ,wheel diameter and wheel tread;
- 9、 Back key :back to last step
- 10、 Start key
- 11、 Stop key

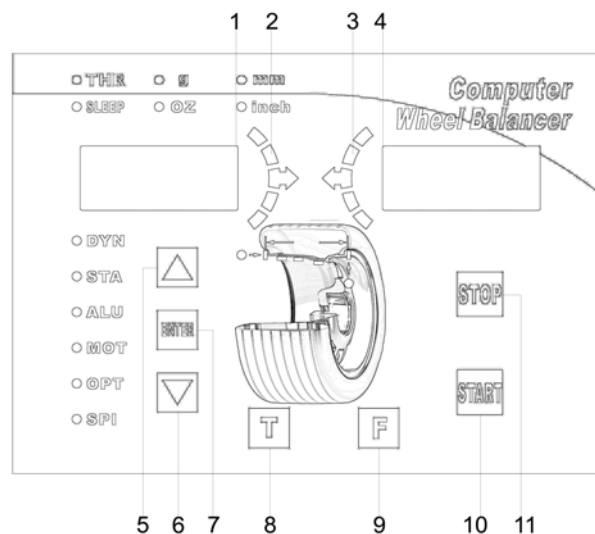

fig 6 display panel structure

Four balancer operation

4.1 Start

Turn on the power switch,as the sound of “di”,the wheel balancer starts testing,then the inside and outside screen all display 000(fig 7),The program goes into”DYN balance”item,waiting for your next operation.

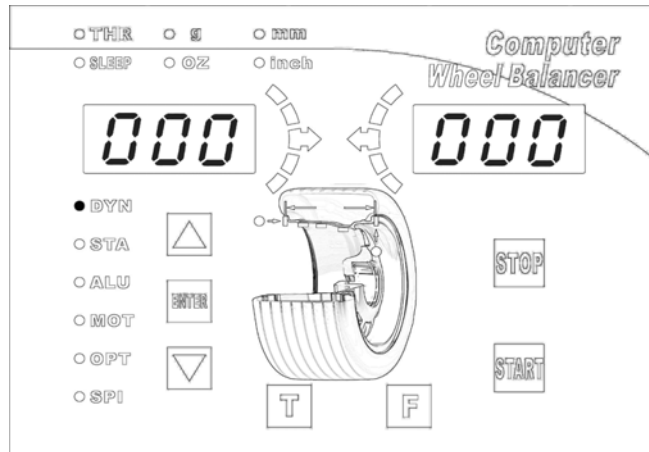

Fig 7 normal start status

4.2 Wheel installation

(1) .Put the wheel on the balance shaft ,near to the flange. (2)select a suitable cone and put it on the stub shaft,fasten the wheel with quick nut (fig 8)

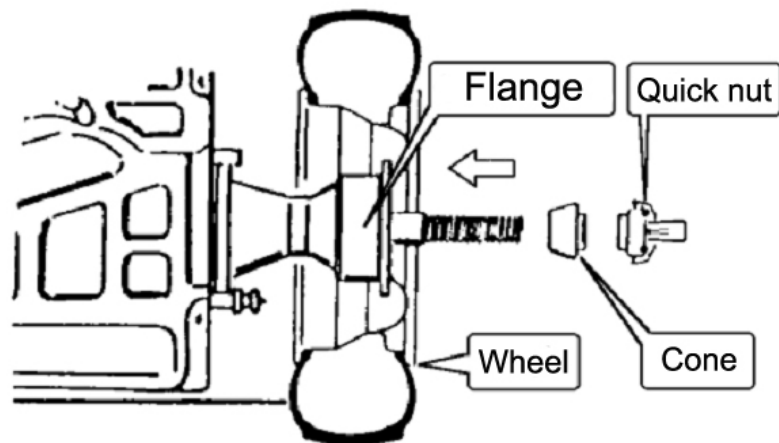

fig 8 wheel installation

4.3 Inputting wheel data

Before all balance operation, you must input correct wheel data (for example: rim diameter: 15 inch, wheel width: 7.5 inch, rim distance: 55mm); it has two ways to input the data, manual input and automatic input for users choice.

4.3.1 Automatic inputting

it can input the mounting distance automatically through the measuring scale, and the rim diameter (wheel diameter). the wheel width data need inputting manually.

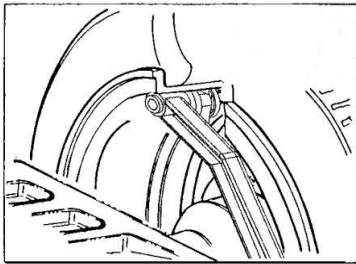

Fig 9

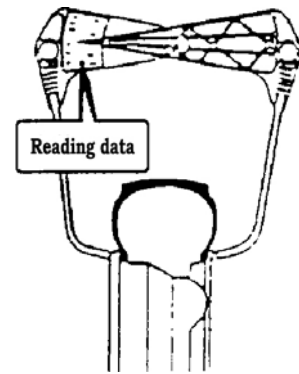
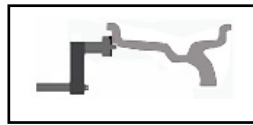

fig 10 wheel width measuring

- 1、 pull out the automatic scale, make the scale head touch with the inside rim (fig 9)
- 2、 after display Lr 6.5 , return back the scale. (system identified wheel width is 6.5 ")
- 3、 use wheel width scale to measure the width (fig 10), Press **【 ↑ ↓ 】** to input real wheel width, data inputting finish.

4.3.2 Manual inputting

under normal start status, Press **【 T 】** key can adjust the wheel diameter , wheel width, and wheel distance data (fig 12), Press **【 ↑ 】** or **【 ↓ 】** key to adjust the data, detailed operation steps as follow.

- 1、 Press **【 T 】** key, displays wheel width Lr 6.5, Then press upper key, adjust the wheel width to 7.5
- 2、 Press **【 T 】** key, The rim diameter displays 14, then press upper key to adjust the di data to 15.

Press **【 T 】** key, displays wheel distance d is 75, pull out the automatic scale, put the scale head inside the wheel rim, then press down key to adjust the d data to the real wheel distance 55, After inputting all the data, put down the hood or press **【 START 】** to test.

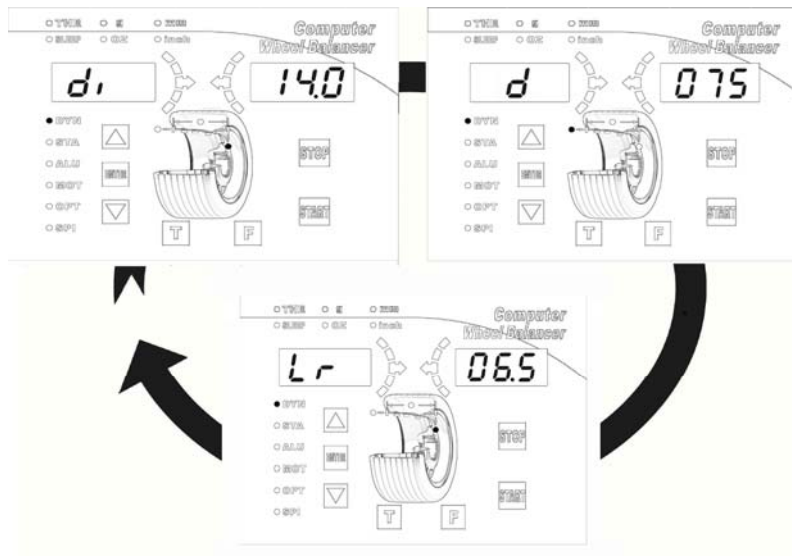

fig 11 wheel data inputting

Note!

- No need to press **START** key after put down the hood for the balancers with hood,it can test automatically ,while the wheel is rotating, don' t uplift the hood. Any abnormity happens, shut down the power first, and uplift the hood after the wheel stops.
- Before balancing the wheel, clean the wheel and take out all the dirt in the wheel gap and rim.Don' t touch the machine while running to avoid affect the testing result.

4.4、Balance function select

4.4.1 DYN balance

It is used to check the imbalanced point of the wheel or steel rim ,and paste relative counter weight lead into the inside or outside wheel to diminish the rotating imbalance. you can go into the DYN balance test item after normal start of the machine,also can press upper key to move to **DYN** balance under other function mode, then press **ENTER** key to go into DYN balance test item,operate as follow:

- 1 Put the wheel on the shaft, input correct wheel data ,put down the hood and press **START** key to make the wheel rotate ,the unbalance data displays as fig 12 after the wheel stops:



Fig 12

- 2 Rotate the wheel by hand, and make the outer side balance indicator flashes in the middle. see fig 13;



fig 13 outside balance indicator flashes in the middle



fig 14 the 12 o'clock position on the rim

- 3 clip the relative 30g counterweight lead onto the tested point on the rim(fig 14)
- 4 rotate the wheel by hand again,make the inside light in the middle,see fig 15
- 5 clip 20g lead inside the rim on the 12 o' clock position(fig 16)



fig 15



fig 16 blance over

- 6 put down the hood or press **START** to test the balance result,the outside display screen all display 00 when the wheel stops(fig 16) ,finish balancing.

4. 4. 2 STA balance

It is designed to test the wheel imbalance on static condition ,which is realized by pasting the counterweight lead on the single point of the rim or the proper positioned center.The imbalance result is only related with the diameter, operation as follow:

- 1、 Under start status,press upper key and move the arrow to STA item ,then press **ENTER** key to go into static balance test program(fig 17).



fig 17

- 2、 Install the wheel,input the wheel diameter,put down the hood and press **START** key to make the wheel rotate,It displays static unbalance data down the wheel stops see fig 18:



fig 18 display STA unbalance data



Fig 19

- 3、 Rotate the wheel by hand ,make the outside balance light in the middle fig 19,clip 25 g lead on the outside or inside of the rim on the 12 o' clock position;
- 4、 Put down the hood or press **START** key to test the balance result , the outside screen displays 00 (fig 17) ,after the wheel stops,the balancing finish.

4.4.3 ALU balance

Rim balance also called alloyed wheel balance, it contains 7 modes, the lead stick side of ALU-1P, ALU-2P can be set by measuring scale. ALU-1, 2, 3, 4, 5 can choose different flat to clip lead according to the rim side, and get precision balance position to gain more precision balance result.

- 1、 Press Upper key to move to ALU item , then press **ENTER** key to go into ALU balance test program, see fig 20



fig 20

- 2、 press UPPER key constantly , it will display as fig 21

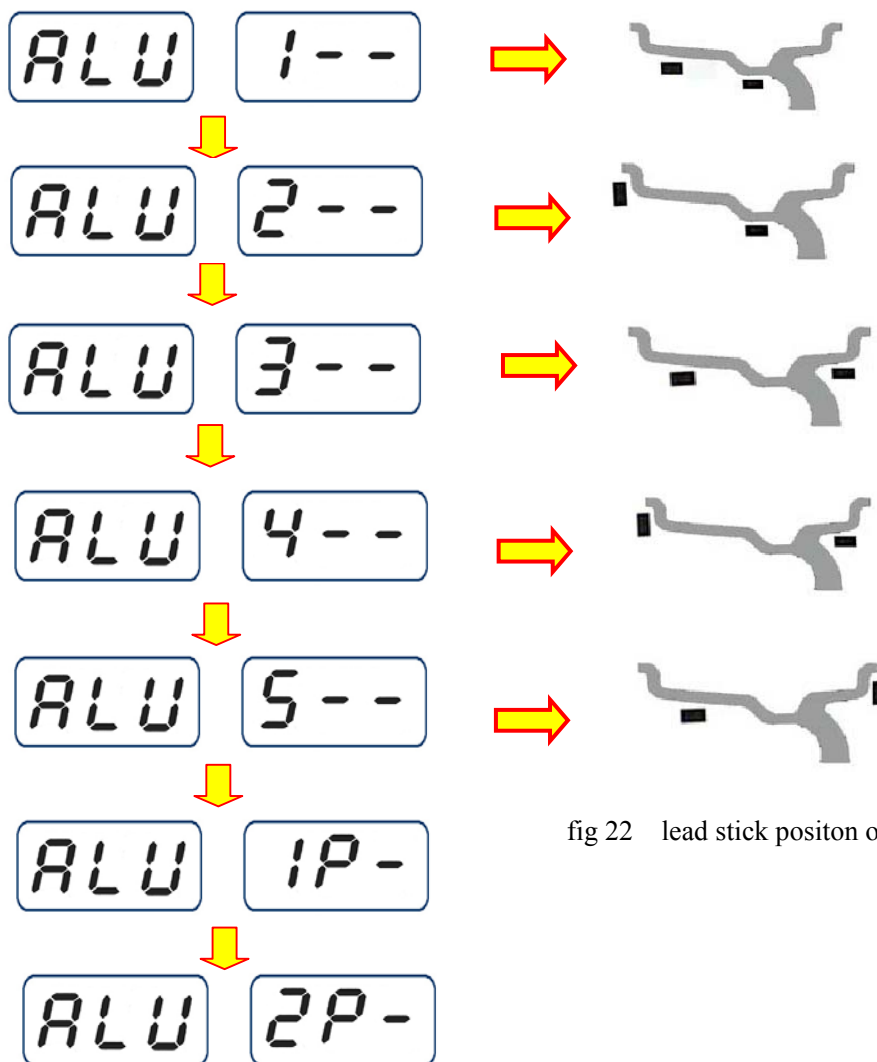

fig 22 lead stick positon of 5 modes

fig 21 7 modes of ALU modes display

Press **ENTER** key can enter relevant program for test

ALU - 1P mode operation as follow:



Press [ENTER] key

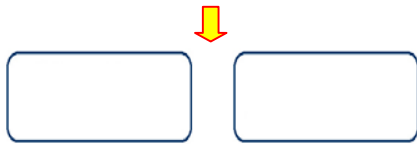

pull out the measuring scale to the position as fig and keep on, Press **[ENTER]** to confirm the first lead stick position.

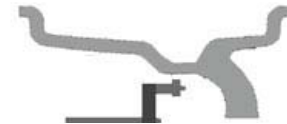

pull the scale again to the second lead stick position, press ENTER to confirm the second lead stick position

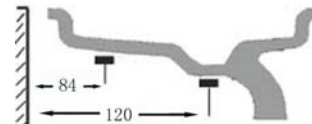

after the scale comeback, start **START** key to rotate the wheel

after wheel stops it will display the balance result; inside 18g, outside 40g unbalance.



rotate the wheel and make the inside direction light flash centered



pull out the scale, clip 18g lead on the scale head position when the outside data reduce from 84 to 0, make the scale come back



rotate the wheel again to make the outside balance direction light flash centered



pull out the measuring scale, clip 40g lead on the scale head when the inside data reduce from 120 to 0, make the scale come back, press **START** key



When the wheel stops, both inside and outside are display 000, the test over .

All ALU-2P operation are the same as ALU-1P except for clip lead inside.

The rim balance ALU-1, 2, 3, 4 and 5 , five pasting and clipping methods are designed in the program of the wheel balancer, which includes the common used balance ways. The operation procedures are the same as that of dynamic balance excluding the balance point.

according to the sum up of the wheel specification, the minimum width of the pasting or clipping points of ALU-1, 2, 3, 4, 5 is :

ALU—1	ALU—2	ALU—3	ALU—4	ALU—5
≥120mm	≥96mm	≥74mm	≥63mm	≥59mm

Note:If there is still less than 10g unbalance after rotating test, you can adjust the balance lead right or left properly to gain better balance result.

4. 4. 4 MOT balance

Motorcycle wheel can be balanced by static balance method, which divides the counterweight lead equally divided into two parts, and paste then onto the inner and outer side of the rim .but this method is not suitable if the rim width exceed “3” ,in this case, the user can apply” motorcycle wheel balance” program ,it includes motorcycle dynamic balance and motorcycle static balance.

1、 Under normal start status, press upper key to move the arrow to MOT item ,press **ENTER** to go into the motorcycle wheel test program

Note: To use this function, user must purchase motorcycle adapter then motorcycle balance can be done, detailed function operation see the motorcycle adapter instruction.

4.4.5 OPT balance

This program is to define the best match position of steel rim and outer tire, and make compensation of the imbalance rim and imbalance tire, so as to decrease the lead weight and reduce the noise caused by unmatched rim and tire.

Under DYN balance, press **【↑】** key to move the arrow to OPT item ,then press **ENTER** key to go into SPI test program.

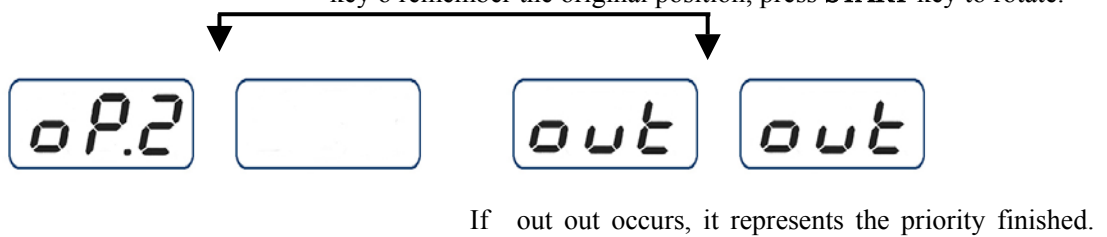
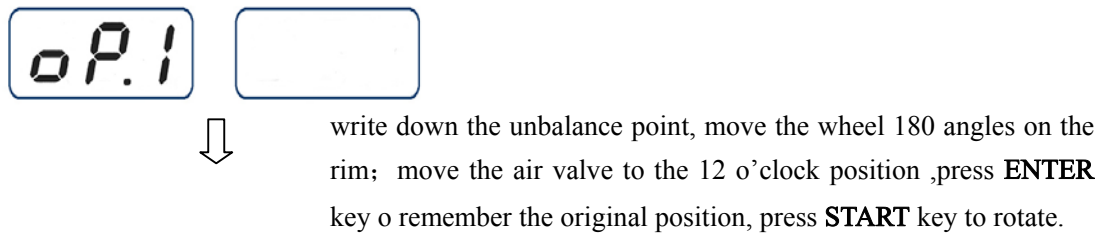
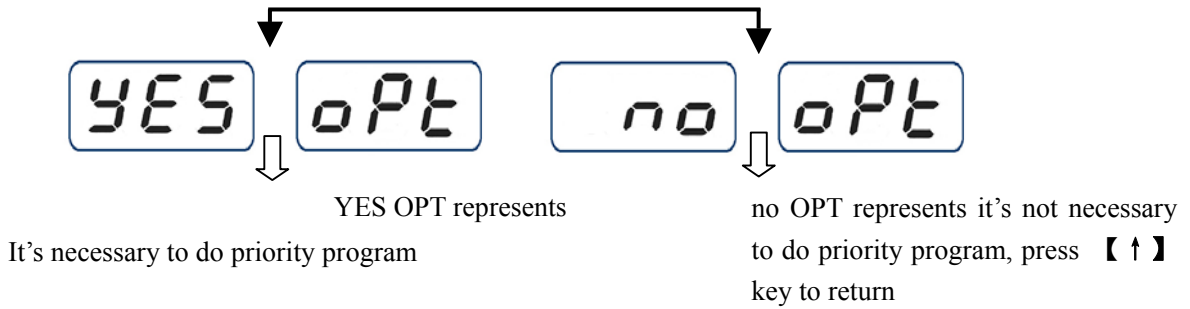

Press **【↑】** to withdraw.

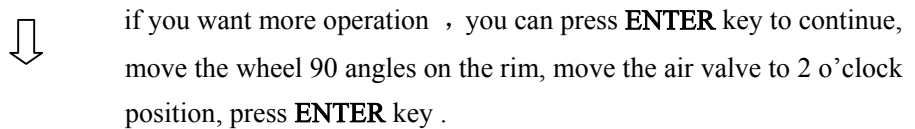

Press **【START】** key to rotate

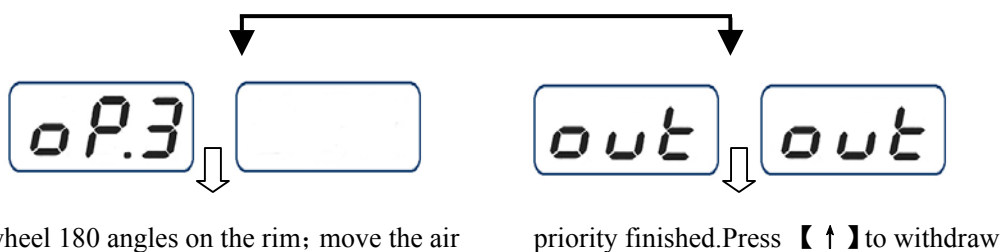

when the wheel stops, the priority finish, the program will return back to DYN balance status automatically, and the balance can be finished conform to DYN balance operation.

Note: in priority program, press 【↑】 key to to exit the priority program, return back to the DYN balance status. Press 【ENTER】 ,then after “out out” appears, next step can be done.

4.4.6 SPI balance

This program is an assistant program for mode ALU-1P,2P of rim balance, to divide the counterweight lead pasted between spokes on luxury car into two different weight leads automatically, which can be hidden behind the spoke. This function makes the spoke wheel of look more beautiful, and is more applicable for luxury cars.

First conform ALU-1P or ALU-2P (necessary term)

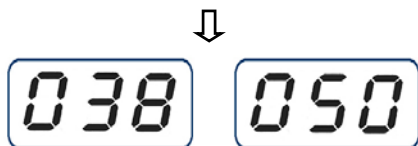

For example: inner imbalance value is 38g
Outer imbalance value is 50g

Press **【↑↓】** key to select "SPI", press **【ENTER】** key to enter

rotate the wheel manually to make the outside unbalance light flash centered, mark the unbalance point (the position where the scale points)



move the line adjacent to the unbalance point to the 12 o'clock position

press **【ENTER】** to confirm

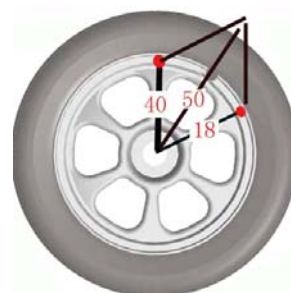

move the other line adjacent to the unbalance point to the 12 o'clock position (same as above)

press **【ENTER】** key to finish the SPI

divide 50 g balance to 40g and 18g



rotate the wheel by hand, and keep the indicator centered, use measure scale to find the second spoke, and paste 40g weight on the position measure scale head touched.

go on rotating the wheel



make the outside indicator centered again, pull out the scale to make sure the second line and paste 18g lead;

press **【START】** to rotate

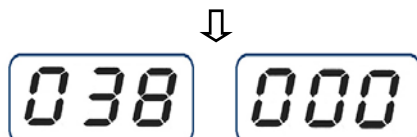

outside unbalance is 0, SPI finish

Five:set program

5.1 Transfer of g/ounce

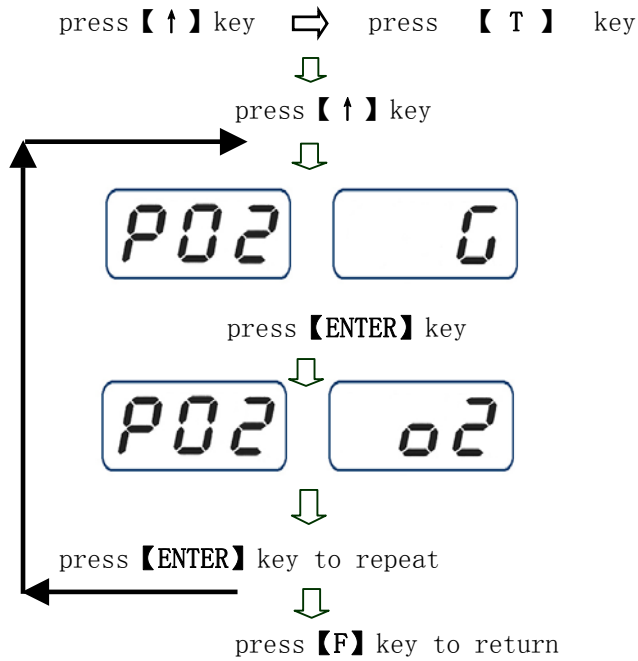

5.2 Scale calibration

first, the scale must be at the original position, press **【 ↑ 】** key, then press **【 T 】** key

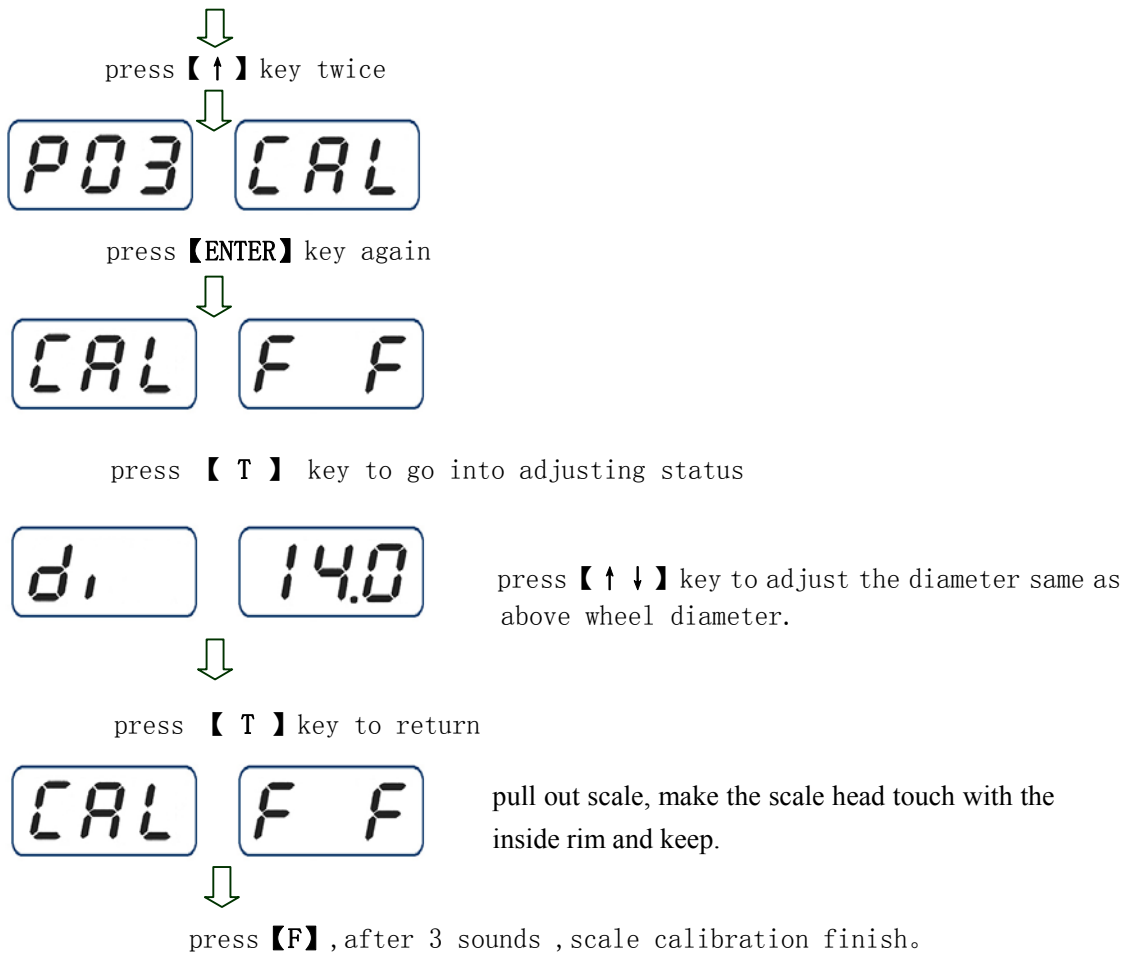

Note: If the error code "Err 20" occurs, it means the scale is not in the correct position when calibrating, then, put the scale in the correct position and repeat calibration program.

5.3 Weight calibration

when "Err CAL" code occurs while self-calibration or balance weight occurs error, user can use this calibration program to amend the error. choose a wheel with smaller unbalance value and mount on the machine. input correct wheel data (distance d, width l, diameter dl).

NOTE: correct wheel data must be input before calibration, the position where to clip 100g lead must be correct

- 1 press **【↑】** key then press **【T】** key, press **【↑】** key four times;



- 2 press **【ENTER】** key to go into weight calibration program;

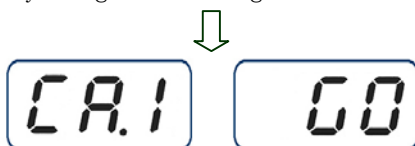

- 3 take off the 100g lead, put down the hood or press **【START】** key to let the wheel rotate again, it will display when stops;

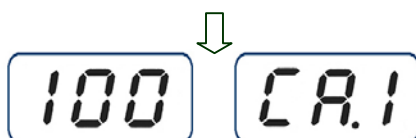

- 4 rotate the wheel to make the inside indicator centered, clip 100 g lead on the 12 o'clock position inside the rim;
- 5 put down the hood and press **【START】** key to let the wheel rotate again, it will display when stops;

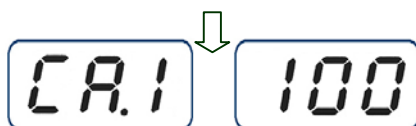

- 6 rotate the wheel to make the outside indicator centered; clip 100 g lead which is taken off from inside on the 12 o'clock outside the rim
- 7 put down the hood or press **【START】** key to let the wheel rotate again, it will display 000 when stops, calibration over.

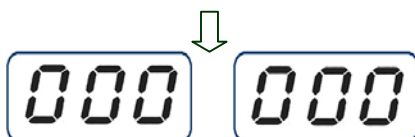

Six .Common trouble information and shooting

6.1、 Trouble code information and shooting

Error code	Cause	Solution
Err CAL	Self-calibration error occurs in the wheel balancer system, it is mainly caused by the new no-calibrated of the wheel balancer or not calibrate after changing new main board.	1、make weight calibration again for the machine
Err 5	The balancer occurs self-calibration error. it' s mainly caused by no calibration of the new system balancer or no calibration after changing new main board	1、calibrate scale again for the machine
ALU Err	In rim balance ,when balance the rim,input incorrect data	2、 input correct rim size.
Cr Err	forget to put down the hood for balancer with hood, or forget to connect the hood connection wire for balancer without hood.	3、 put down the hood or connect the hood cable is OK.
CCC CCC	Unbalance data over 255g	1、 change a wheel with smaller unbalance data and test again; 2、 make self-calibration again;

6.2、 Other trouble and shooting

NO	trouble	cause	solution
1	Balancer display board has no light, there is no reaction when pressing any key	If the power switch is not light, it proves the socket doesn' t work	a. Check the circuit, plug and socket
2	When operate START key, the wheel can not rotate	The hood connection wire brake off or the hood is not put down.the connection wire is not connected for the balancer without hood	Connect the hood wire well or put down the hood. connect the cable for balancer without hood
3	Balance data is not correct	a. machine vibrates when rotating b. machine is not placed stable c. wheel is not clipped tightly d. incorrect data inputting e. machine is not calibrated	Adopt correct solution to operate again according to the actual situation

Seven . Balancer wire connection drawing

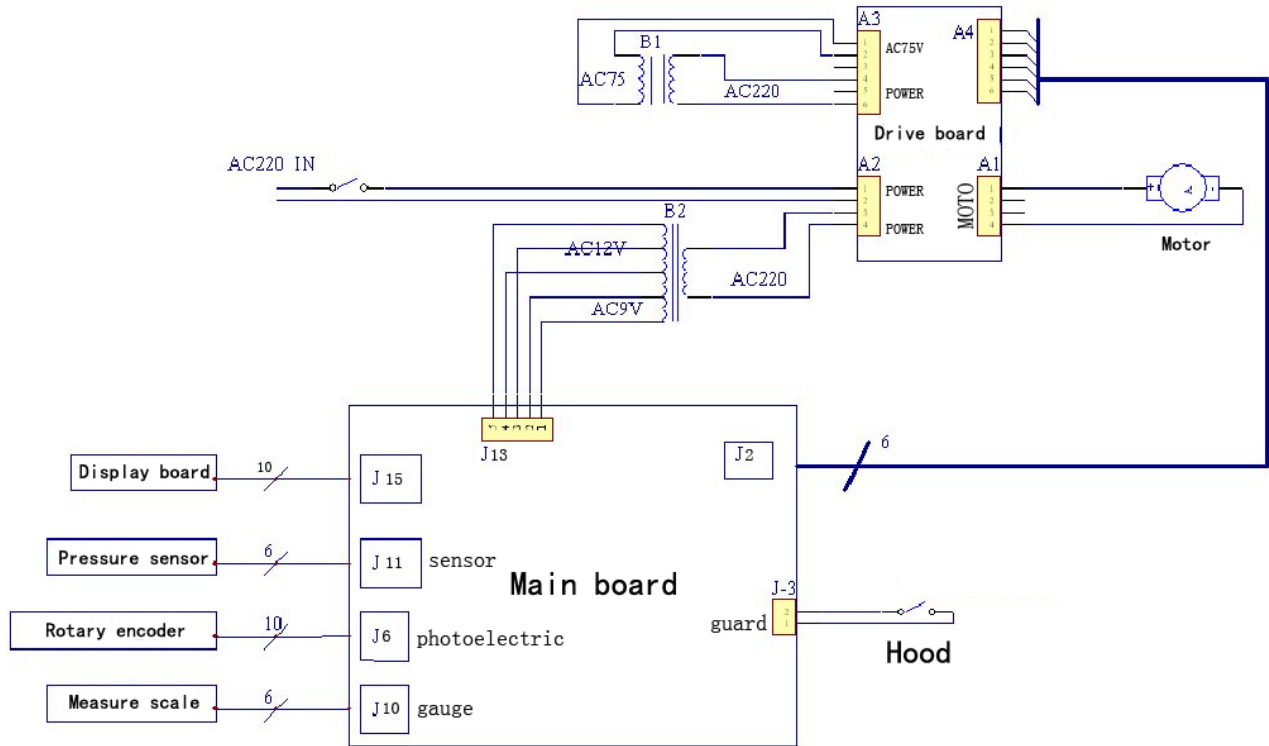

Eight. 1300 explode drawing

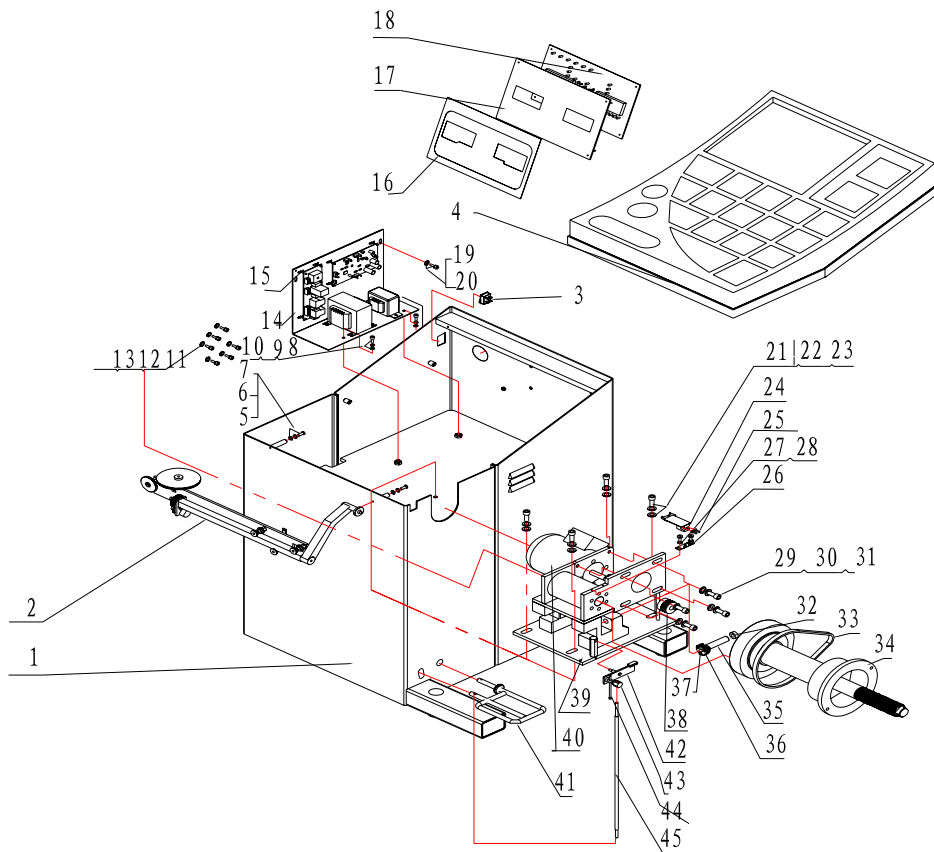

1300 Balancer main parts

NO.	Name	Qua	Code	NO.	Name	Qua	Code	NO.	Name	Qua	Code
1	Main Frame	1	621+001	16	Display film	1	621+016	31	Spring washer	4	621+031
2	Rod Assembly	1	621+002	17	Inner plate	1	621+017	32	Nut	2	621+032
3	Switch	1	621+003	18	Display board	1	621+018	33	Belt	1	621+033
4	Cover	1	621+004	19	Spring washer	6	621+019	34	Balance shaft	1	621+034
5	Bolt	2	621+005	20	Bolt	6	621+020	35	Bolt	2	621+035
6	Spring washer	2	621+006	21	Bolt	4	621+021	36	Pressure sensor	2	621+036
7	Flat washer	2	621+007	22	Spring washer	4	621+022	37	Ball bearing	2	621+037
8	Bolt	2	621+008	23	Flat washer	4	621+023	38	Pulley	1	621+038
9	Spring washer	2	621+009	24	Rotary encoder	1	621+024	39	Suspension Assembly	1	621+039
10	Flat washer	2	621+010	25	Bolt	2	621+025	40	Motor	1	621+040
11	Bolt	6	621+011	26	Bracket	1	621+026	41	Foot Brake	1	621+041
12	Flat washer	6	621+012	27	Bolt	1	621+027	42	Brake base	1	621+042
13	Spring washer	6	621+013	28	Flat washer	1	621+028	43	Spring Shaft	1	621+043
14	Electrics fixing plate unit	1	621+014	29	Bolt	4	621+029	44	Foot Press Spring	1	621+044
15	Holder	8	621+015	30	Flat washer	4	621+030	45	Foot Brake Link	1	621+045

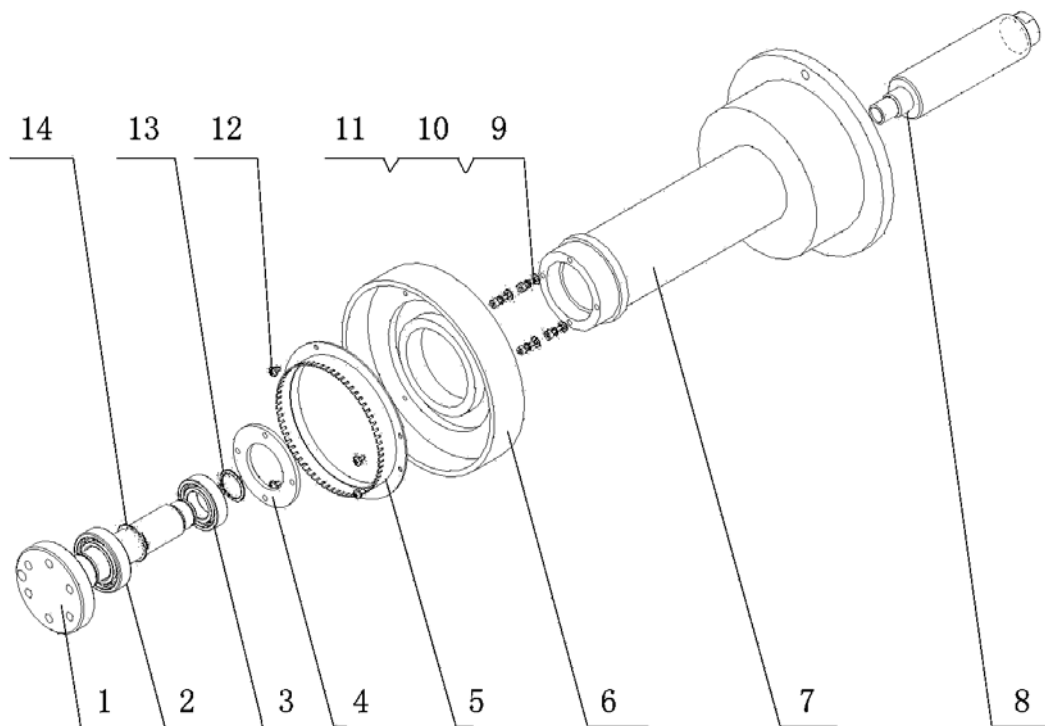

1300 Balance wheel parts

NO.	Name	Qua	Code	NO	Name	Qua	Code
1	Supporting shaft	1	621+046	8	Stub shaft	1	621+053
2	Bearing	1	621+047	9	Inner hex screw	4	621+054
3	Bearing	1	621+048	10	Flat washer	4	621+055
4	Bearing cover	1	621+049	11	Spring washer	4	621+056
5	Rotary plate	1	621+050	12	Screw	4	621+057
6	Attrition wheel	1	621+051	13	Spring washer	1	621+058
7	Balance wheel	1	621+052	14	Spring washer	1	621+059

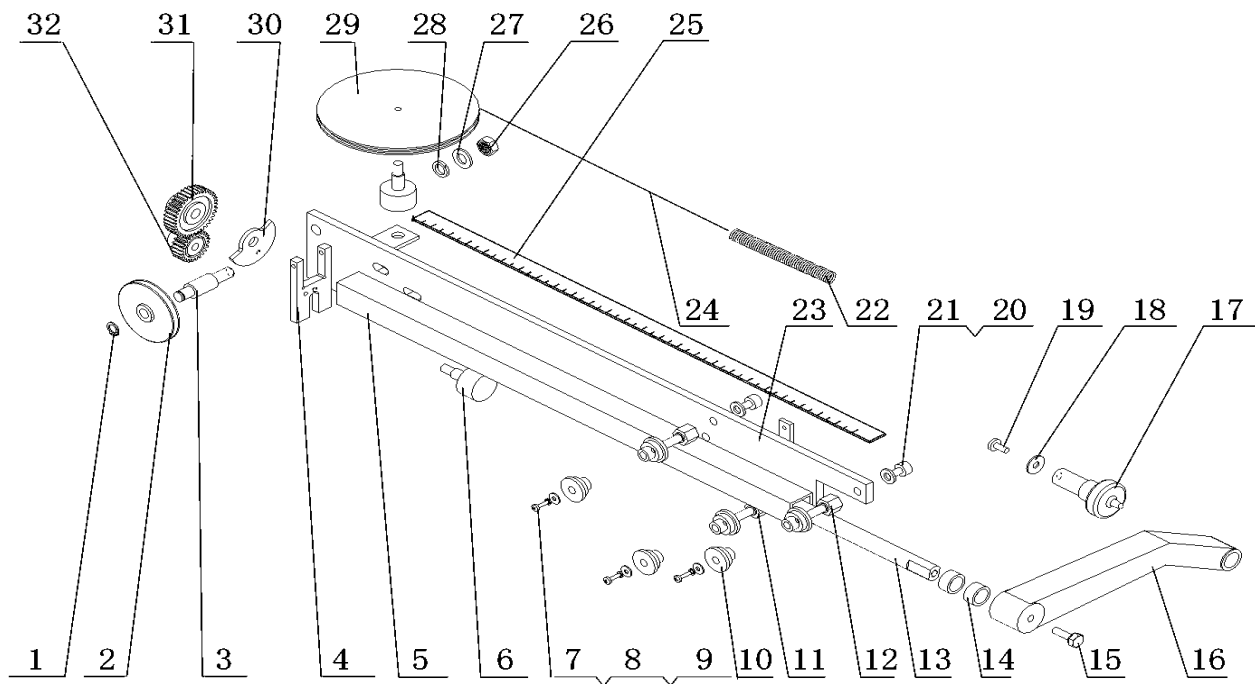

1300 Measuring scale parts

NO.	Name	Qua	Code	NO.	Name	Qua	Code
1	Elastic washer for shaft	1	621+060	17	Scale head	1	621+076
2	Small roller	1	621+061	18	Washer	1	621+077
3	Small roller bracket	1	621+062	19	Screw	1	621+078
4	Gear fixing rack	1	621+063	20	Screw	3	621+079
5	Scale bracket	1	621+064	21	Flat washer	3	621+080
6	Encoder	2	621+065	22	Spring	1	621+081
7	Screw	3	621+066	23	Scale rack frame parts	1	621+082
8	Elastic washer	3	621+067	24	Steel wire assembly	1	621+083
9	Washer	3	621+068	25	Scale sticker	1	621+084
10	Pulley	6	621+069	26	Sscrew	1	621+085
11	Pulley shaft 2	1	621+070	27	Flat washer	1	621+086
12	Pulley shaft 1	2	621+071	28	Elastic washer	1	621+087
13	Scale bracket core	1	621+072	29	Wire roller	1	621+088
14	Scale bracket cover	2	621+073	30	Limited plate	1	621+089
15	Hex screw	1	621+074	31	Big gear	1	621+090
16	Measuring arm	1	621+075	32	Small gear	1	621+091

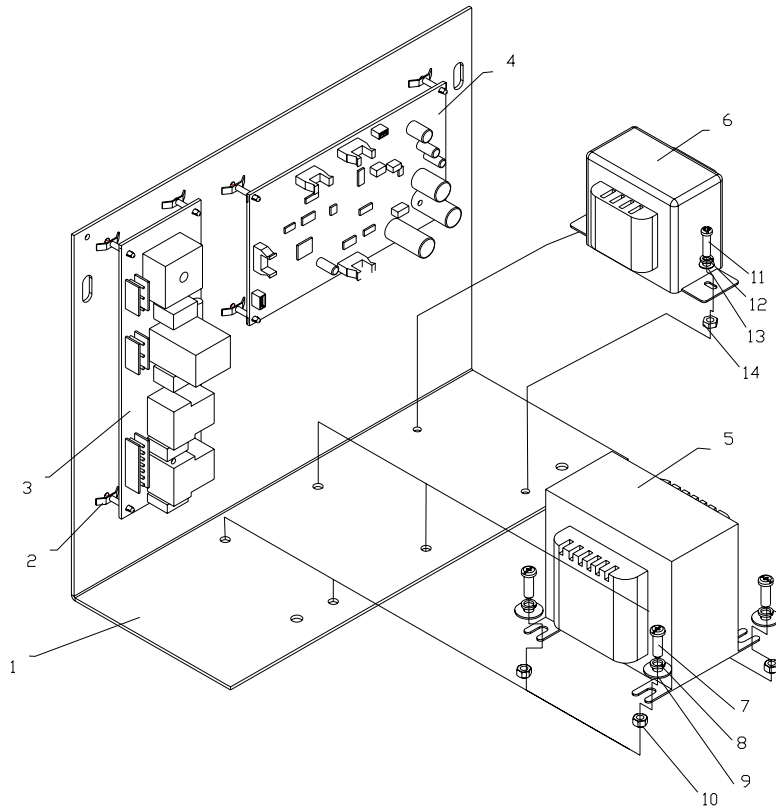

1300 Electrics fixing plate parts

NO.	Name	CODE	Qua	NO.	Name	Code	Qua
1	Electrics fixing plate	621+092	1	8	Spring washer	621+099	4
2	Bracket	621+093	8	9	Flat washer	621+100	4
3	Drive board	621+094	1	10	Screw	621+101	4
4	Main board	621+095	1	11	Screw	621+102	2
5	Big transformer	621+096	1	12	Spring washer	621+103	2
6	Small transformer	621+097	1	13	Spring washer	621+104	2
7	Screw	621+098	4	14	Screw	621+105	2